

SIDE SECTION VIEW

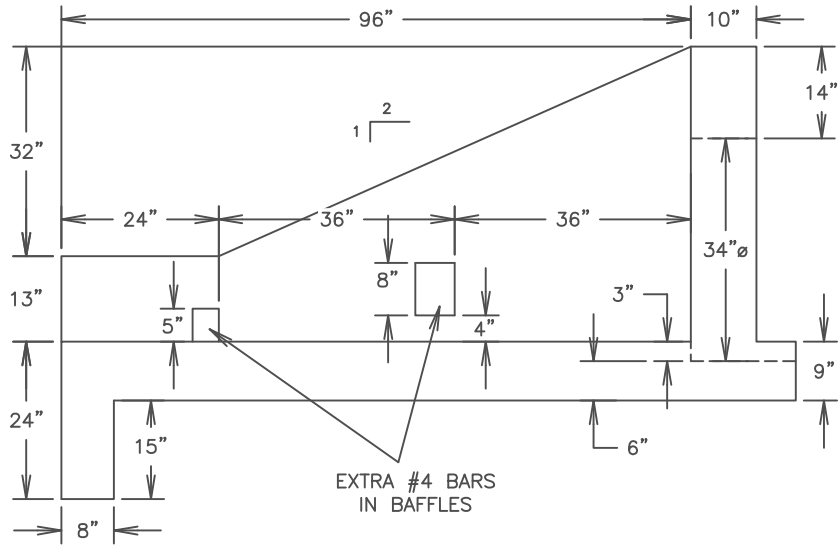

FRONT VIEW

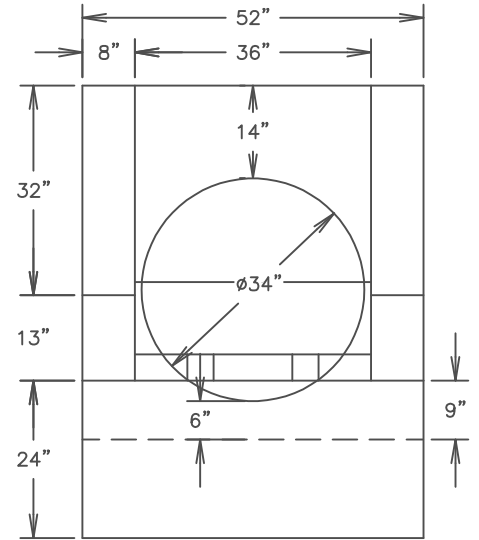

SIDE SECTION VIEW

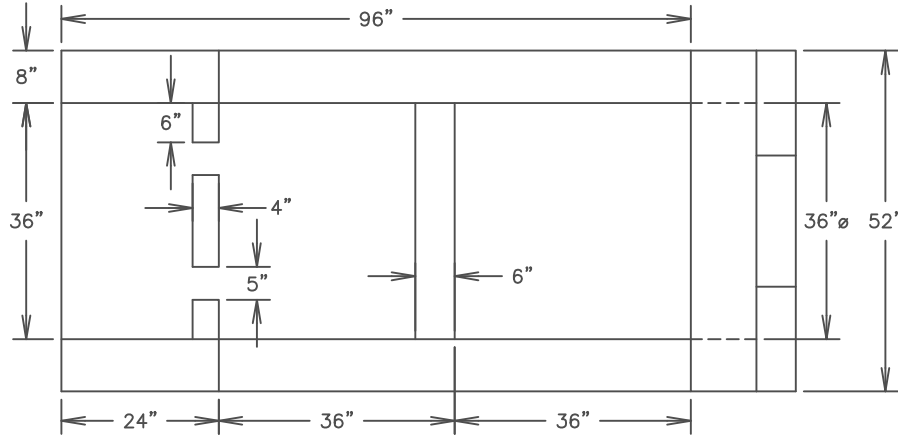

ENDWALL MODIFIED SLIGHTLY FROM FDOT SPECIFICATION TO FIT REQUIRED PIPE BLOCKOUT AS WELL AS RETAIN 2:1 SLOPE  
SEE FDOT INDEX #430-011 FOR MORE INFO.

**REINFORCEMENT**  
HORIZONTAL: #4 BARS @ 12" O.C.  
VERTICAL: #4 BARS @ 12" O.C.

**STRUCTURE QUANTITIES**  
APPROXI. CONCRETE: 2.44 cy±  
APPROX. WEIGHT: 9,850 lbs±

NOT TO SCALE  
DIMENSIONS SUBJECT TO  
SITE SPECIFIC CHANGES.



DWG. NO.	24 RCP U-TYPE ENDWALL
SCALE	NTS
PROJECT #	21-19902

PROJECT	LYLE MACHINERY PENSACOLA
CUSTOMER	HUGHES UNDERGROUND

DATE	2/8/2022
DRAWN BY	JJC