

TOP VIEW

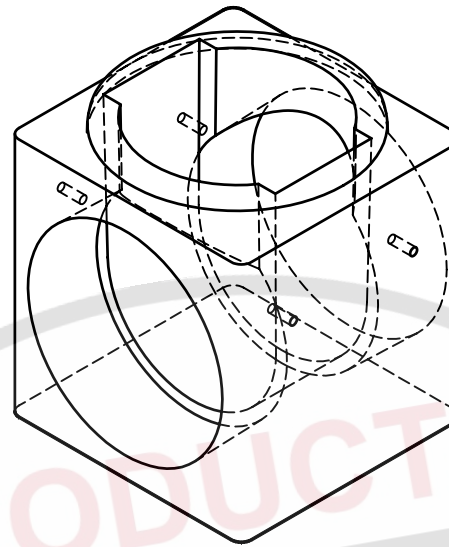

Structure manufactured to ASTM C 478 and/or C 913.

Reinforcing conforms to either ASTM A 185 for wire mesh or A 615 (Gr 60) for reinforcing bars.

4000 PSI concrete minimum.

Equipped with two S206-54L boots for use with 48" ductile iron pipe.

Transition top to 60" diameter for flat top or stack out.

Approximate weight: 8.1 tons.

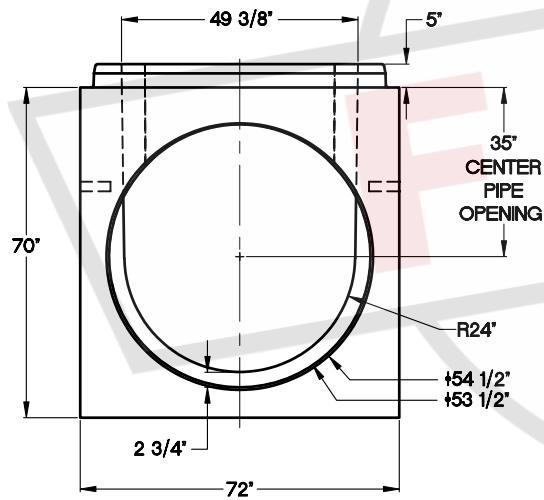

FRONT VIEW

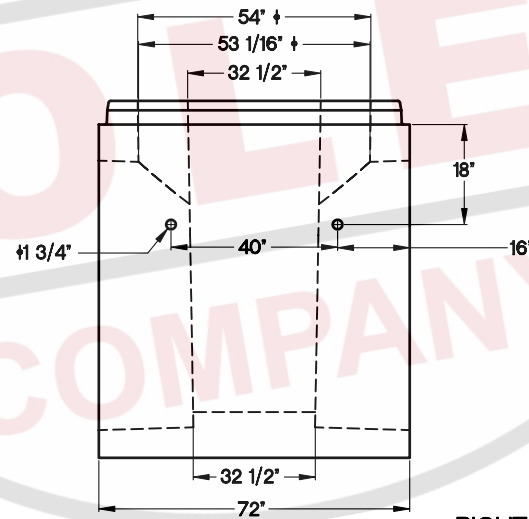

RIGHT VIEW



208 JEFFERSON STREET
NEWNAN, GEORGIA 30263
(770) 251-0296

48"-0° Ductile Iron Transition Base

SECTION	D. I. TRANSITION	DATE	02-24-02	REVISION	
SCALE	NTS	DRAWN BY	EFD	PAGE #	11-10