

ID	WT	FLAT TOP	TONS	RISER SECTION			BASE SECTION		
				MAX	MIN	VF TONS	MAX	MIN	SLAB TONS
60"	6"	8"	1.41	5'-0"	1'-0"	0.65	5'-6"	2'-0"	1.41
72"	7"	9"	2.27	6'-0"	1'-0"	0.91	6'-6"	3'-0" **	2.02
84"	7"	12"	3.93	8'-0"	2'-0" *	1.04	8'-6"	3'-0" **	1.04
84"	8"	12"	4.09	N/A	N/A	N/A	7'-6"	3'-0" **	2.73
96"	9"	12"	5.32	8'-0"	2'-0" *	1.55	8'-6"	3'-0" **	3.54
120"	10"	12"	8.02	6'-0"	3'-0" **	2.13	5'-0"	2'-0"	10.69
120"	11"	12"	8.25	8'-0"	3'-0" **	2.36	7'-0"	2'-0"	11.00
144"	12"	12"	11.55	6'-0"	3'-0" **	3.06	5'-0"	2'-0"	17.32

1'-0" AVAILABLE UPON REQUEST \*  
 2'-0" AVAILABLE UPON REQUEST \*\*

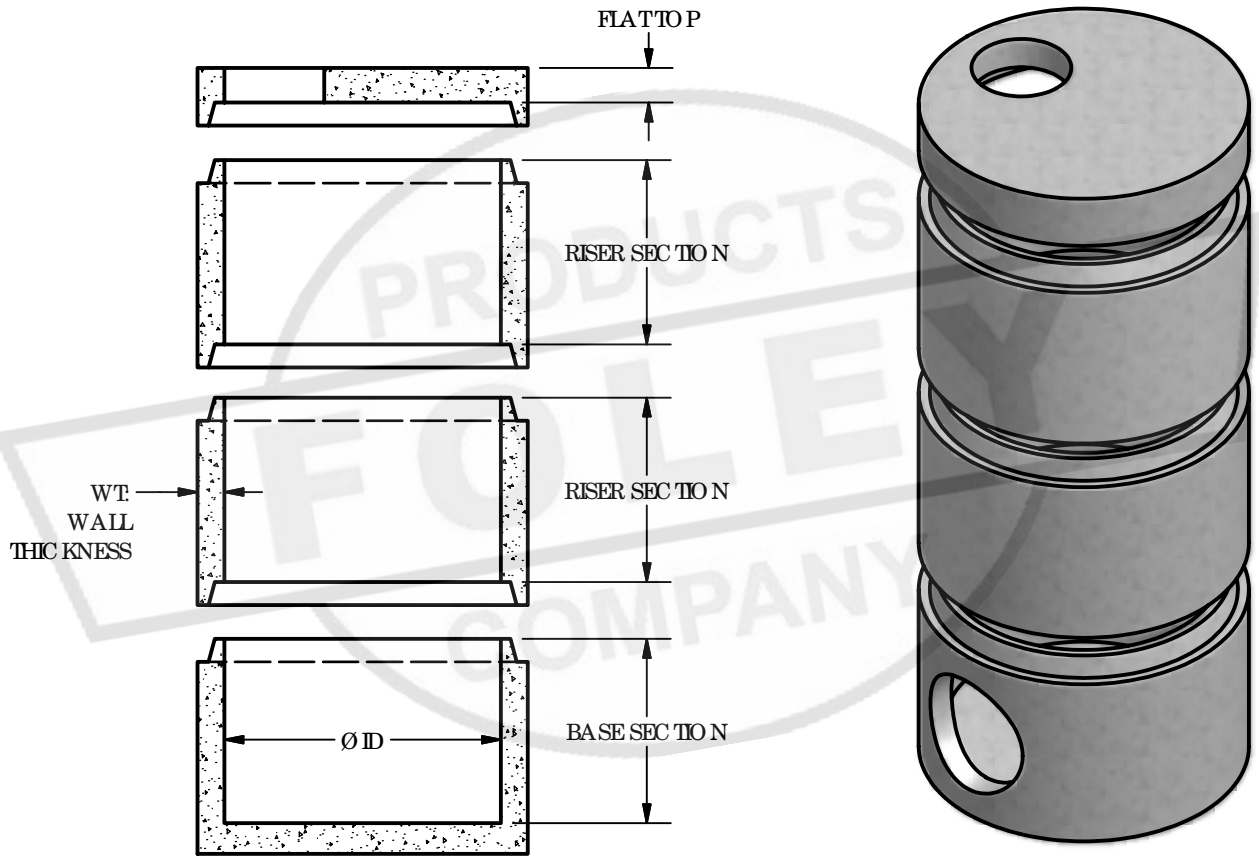

**MATERIALS:**

CONCRETE: 4,000 PSI TYPE I/II CEMENT  
 REINFORCEMENT PER ASIM C-478

**NOTES:**

FLEXIBLE CONNECTIONS ARE AVAILABLE

**PARTS SHOWN:**

- Ø 72" (7") FLAT TOP
- Ø 72" (7") 4'-0" RISER
- Ø 72" (7") 4'-0" RISER
- Ø 72" (7") 4'-0" BASE W/ Ø 34" HOLE



**ROUND PRECAST**

LARGE DIAMETER WETWELL

**1.8**