

ID	WT	BS	RS	LIP	RISER SECTION			BASE SECTION		
					MAX	MIN	VF TONS	MAX	MIN	SLAB TONS
60"	6"	8"	12"	5"	5'-0"	1'-0"	0.65	5'-6"	2'-0"	1.41
72"	7"	8"	12"	6"	6'-0"	1'-0"	0.91	6'-6"	3'-0" **	2.02
84"	7"	8"	12"	7"	8'-0"	2'-0" *	1.04	8'-6"	3'-0" **	1.04
84"	8"	8"	12"	7"	N/A	N/A	N/A	7'-6"	3'-0" **	2.73
96"	9"	8"	16"	7½"	8'-0"	2'-0" *	1.55	8'-6"	3'-0" **	3.54
120"	10"	16"	18"	4"	6'-0"	3'-0" **	2.13	5'-0"	2'-0"	10.69
120"	11"	16"	18"	4"	8'-0"	3'-0" **	2.36	7'-0"	2'-0"	11.00
144"	12"	18"	18"	6"	6'-0"	3'-0" **	3.06	5'-0"	2'-0"	17.32

1'-0" AVAILABLE UPON REQUEST *
2'-0" AVAILABLE UPON REQUEST **

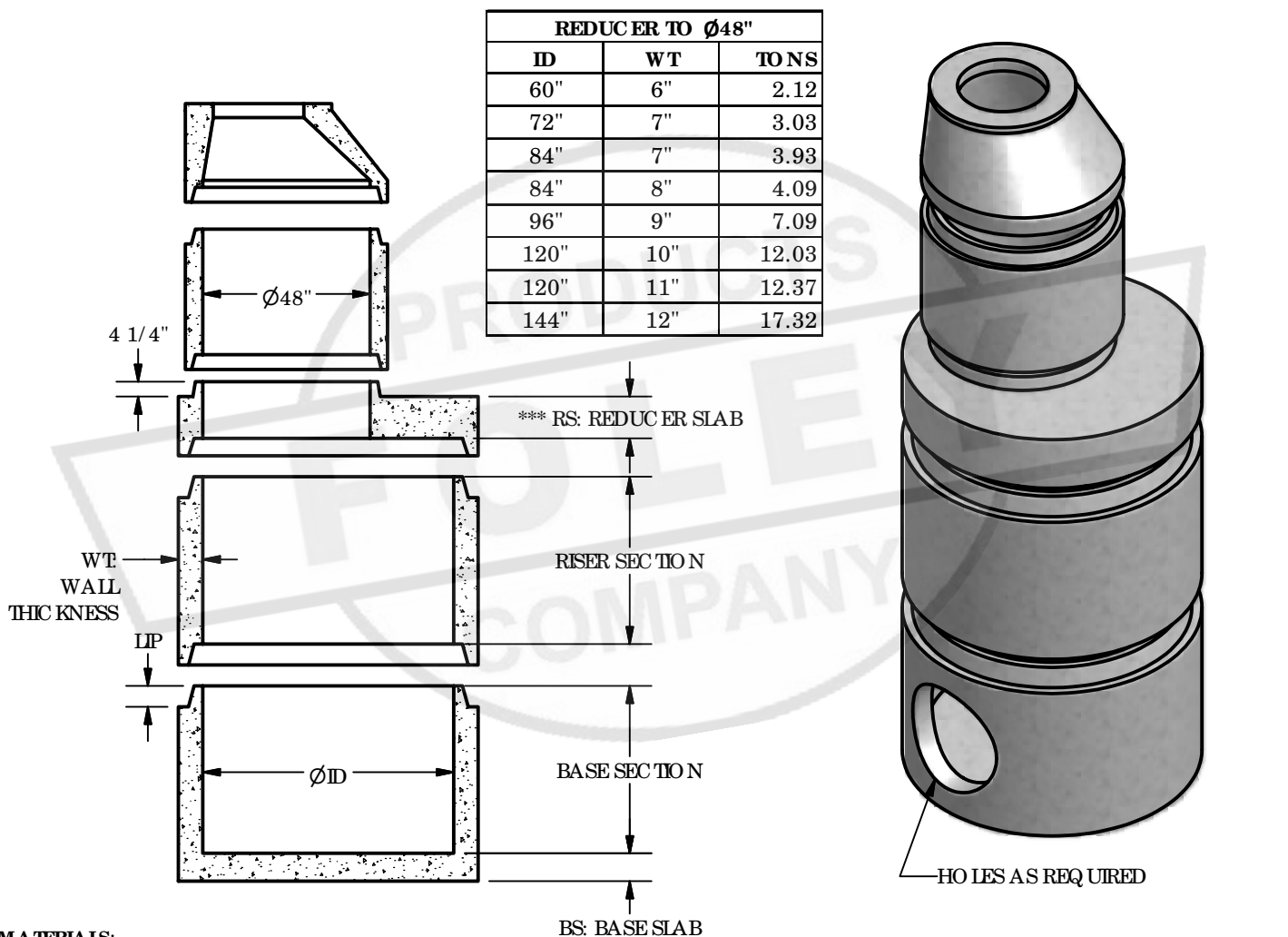

MATERIALS:

CONCRETE: 4,000 PSI, TYPE I CEMENT
REINFORCEMENT PER ASTM C-478
*** SPECIAL DESIGN FOR DEPTHS > 20'

NOTES:

FLEXIBLE CONNECTIONS ARE AVAILABLE

PARTS SHOWN:

- Ø48" (5") 2'-0" ECCENTRIC CONE
- Ø48" (5") 3'-0" RISER
- Ø72" (7") TO Ø48" (5") REDUCER SLAB
- Ø72" (7") 4'-0" RISER
- Ø72" (7") 4'-0" BASE W/ Ø34" HOLE



ROUND PRECAST

Ø60" (6") - Ø144" (12") DIAMETER MANHOLES

1.2