

RISE	WT	A	L	H1	H2	D1	D2	D3	D4	D5	WP1	WP2	TONS
4'	7"	8'	8'-6"	3'-1"	1'-10"	74"					2'-0"		1.88
4'	8"	8'	8'-6"	4'-1"	1'-10"	74"					2'-0"		1.88
5'	7"	8'	8'-6"	4'-1"	2'-10"	74"					2'-0"		2.31
5'	8"	8'	8'-6"	5'-9"	2'-10"	74"					2'-0"		2.31
6'	7"	12'	12'-9.25"	5'-10"	2'-5"	74"	28"	23"			2'-0"	2'-0"	3.66
6'	8"	12'	12'-9.25"	7'-10"	2'-5"	74"	28"	23"			2'-0"	2'-0"	3.66
6'	10"	12'	12'-9.25"	7'-11"	2'-7"	74"	28"	23"			2'-0"	2'-0"	3.76
7'	8"	16'	17'-0.3125"	8'-0"	3'-0"	74"	28"	23"	28"	23"	2'-0"	2'-0"	5.98
7'	10"	16'	17'-0.3125"	8'-3"	3'-2"	74"	28"	23"	28"	23"	2'-0"	2'-0"	6.12
10'	10"	20'	21'-30.375"	8'-3"	3'-9"	74"	28"	23"	28"	74"	2'-0"	2'-0"	9.03

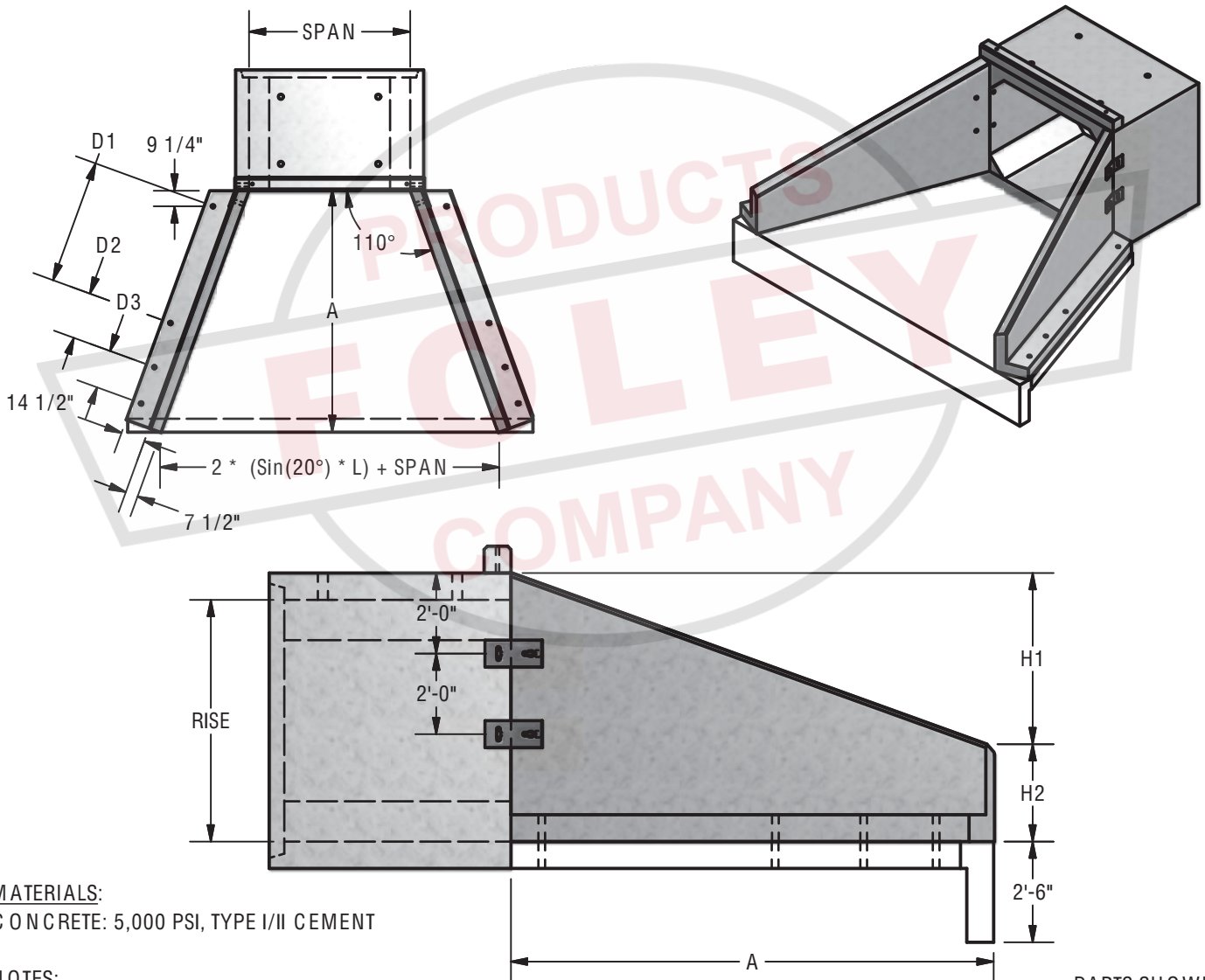

**MATERIALS:**  
 C O N C R E T E : 5,000 P S I , T Y P E I / I I C E M E N T

**NOTES:**  
 A P R O N T O B E P O U R E D I N F I E L D B Y C O N T R A C T O R

**PARTS SHOWN:**  
 S P A N 8 ' x R I S E 6 '



## BOX CULVERT

AL DOT WING WALL STANDARD DETAIL

4.4