

RISE	A	L	H1	H2	D1	D2	D3	D4	D5	D6	D7	D8	D9	D10	D11	D12	D13	D14	D15	TONS
3'	6'	6'-8"	3'-1"	1'-6"	30"	30"														1.52
4'	8'	9'-2"	4'-1"	1'-6"	30"	60"														2.31
5'	8'	9'-2"	4'-1"	2'-6"	30"	60"														2.77
6'	12'	15'-4"	5'-9"	1'-10"	36"	36"	60"													4.13
7'	12'	13'-4"	5'-10"	2'-10"	20"	20"	30"	36"	36"											4.84
8'	16'	18'-4"	7'-10"	1'-10"	15"	20"	20"	30"	48"	66"										6.65
9'	16'	18'-4"	7'-11"	2'-10"	12"	12"	15"	15"	20"	20"	30"	30"	48"							7.60
10'	18'	18'-4"	8'-0"	3'-10"	12"	12"	12"	12"	15"	15"	20"	20"	30"	48"	48"	48"	48"	48"	48"	8.57
11'	20'	23'-0"	8'-3"	2'-10"	13"	45"	31"	20"	20"	20"	15"	15"	15"	12"	12"	12"	12"	12"	12"	8.81
12'	20'	23'-0"	8'-3"	3'-10"	13"	45"	31"	20"	20"	20"	15"	15"	15"	12"	12"	12"	12"	12"	12"	9.88

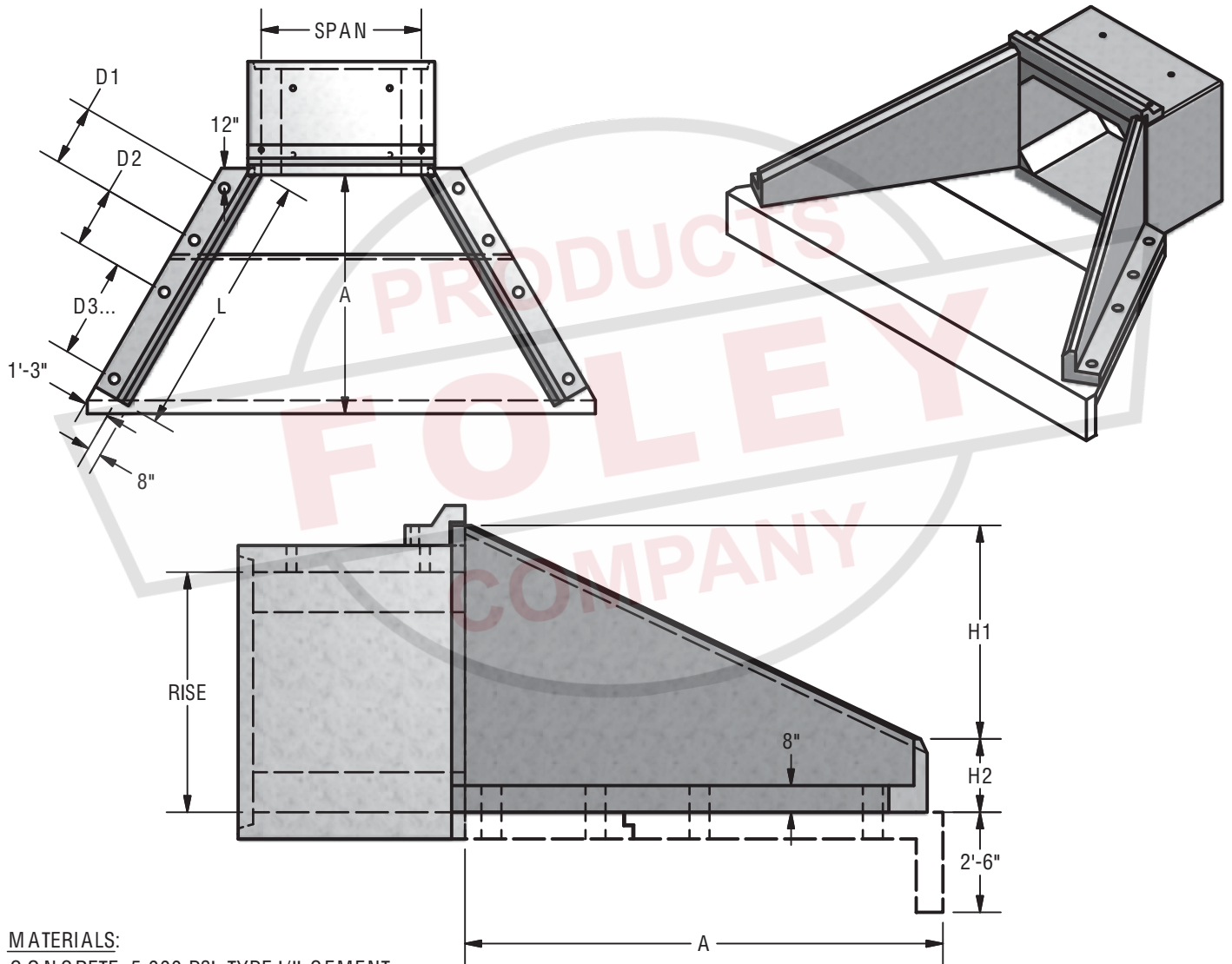

MATERIALS:
 C ONCRETE: 5,000 PSI, TYPE I/II CEMENT

NOTES:
 APRON TO BE POURED IN FIELD BY C ONTRACTOR

PARTS SHOWN:
 SPAN 8' x RISE 6'



BOX CULVERT

WING WALL STANDARD DETAIL

4.2