

ID	WALL	WT	GD	BD	J1	J2	J3	J4	E	L
15"	B	2.25"	18.709"	23.125"	3.5"	1.75"	.326"	.126"	0.875"	6.5"
18"	B	2.50"	21.709"	26.625"	3.5"	1.75"	.326"	.126"	0.875"	6.5"
24"	B	3.00"	27.709"	32.625"	3.5"	1.75"	.326"	.126"	0.875"	7.0"
30"	B	3.50"	34.000"	39.500"	3.5"	1.75"	.326"	.126"	0.875"	7.0"
36"	B	4.00"	40.000"	45.625"	3.5"	1.75"	.326"	.126"	0.875"	7.0"
42"	B	4.50"	46.281"	52.000"	4.0"	2.50"	.446"	.146"	0.875"	7.0"
48"	B	5.00"	52.89"	N/A	4.25"	2.500"	.446"	.0625"	0.750"	N/A
54"	B	5.50"	58.60"	N/A	4.25"	2.500"	.446"	.0625"	0.875"	N/A
60"	B	6.00"	65.10"	N/A	4.75"	2.500"	.446"	.0625"	0.875"	N/A
72"	B	7.00"	77.88"	N/A	5.00"	2.500"	.446"	.0625"	1.250"	N/A

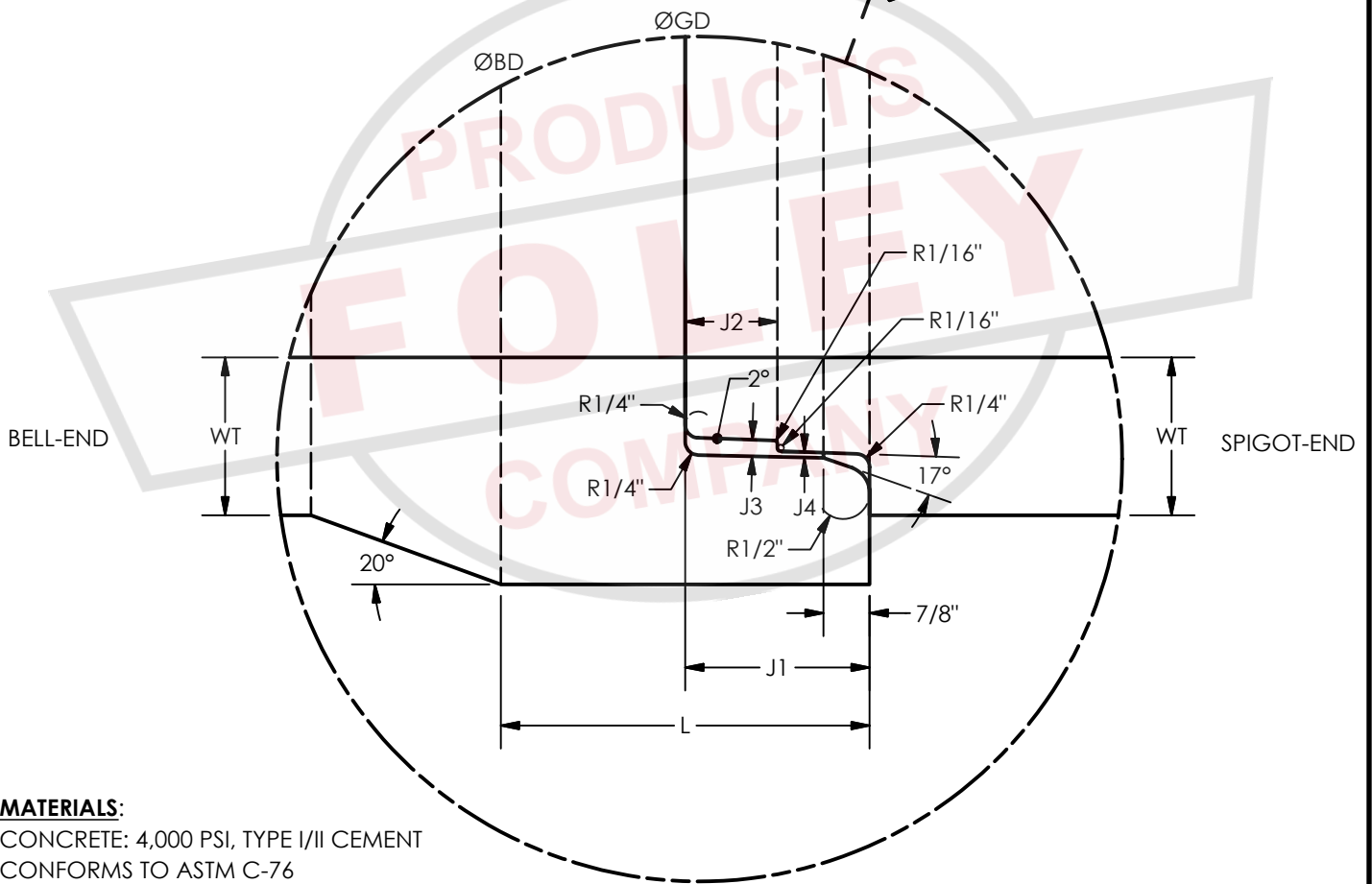
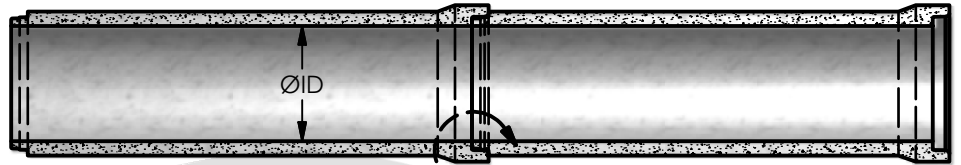

**MATERIALS:**

CONCRETE: 4,000 PSI, TYPE I/II CEMENT  
 CONFORMS TO ASTM C-76  
 JOINT CONFORMS TO ASTM C-443

**NOTES:**

AVAILABLE IN CLASS III, IV AND V

**PARTS SHOWN:**

Ø24" B-WALL



**REINFORCED CONCRETE PIPE**

Ø15" - Ø72" B-WALL PIPE JOINT DETAIL

**3.2**