

SPAN (FT)	RISE (FT)	WALL (IN)	A (IN)	OAW (IN)	TONS PER FT
6	3	7	32	86	1.04
6	4	7	32	86	1.13
6	5	7	32	86	1.22
6	6	7	32	86	1.30

7	3	8	46	100	1.29
7	4	8	46	100	1.39
7	5	8	46	100	1.49
7	6	8	46	100	1.59
7	7	8	46	100	1.69

8	3	8	58	112	1.39
8	4	8	58	112	1.49
8	5	8	58	112	1.59
8	6	8	58	112	1.69
8	7	8	58	112	1.79
8	8	8	58	112	1.89

9	3	9	72	126	1.67
9	4	9	72	126	1.78
9	5	9	72	126	1.90
9	6	9	72	126	2.01
9	7	9	72	126	2.12
9	8	9	72	126	2.23
9	9	9	72	126	2.35

10	3	10	86	140	1.99
10	4	10	86	140	2.11
10	5	10	86	140	2.24
10	6	10	86	140	2.36
10	7	10	86	140	2.49
10	8	10	86	140	2.61
10	9	10	86	140	2.87
10	10	10	86	140	2.99

11	3	11	100	154	2.32
11	4	11	100	154	2.46
11	5	11	100	154	2.60
11	6	11	100	154	2.74
11	7	11	100	154	2.87
11	8	11	100	154	3.01
11	9	11	100	154	3.15
11	10	11	100	154	3.29
11	11	11	100	154	3.43

12	3	12	114	168	2.70
12	4	12	114	168	2.85
12	5	12	114	168	3.00
12	6	12	114	168	3.15
12	7	12	114	168	3.30
12	8	12	114	168	3.45
12	9	12	114	168	3.60
12	10	12	114	168	3.75
12	11	12	114	168	3.90
12	12	12	114	168	4.05

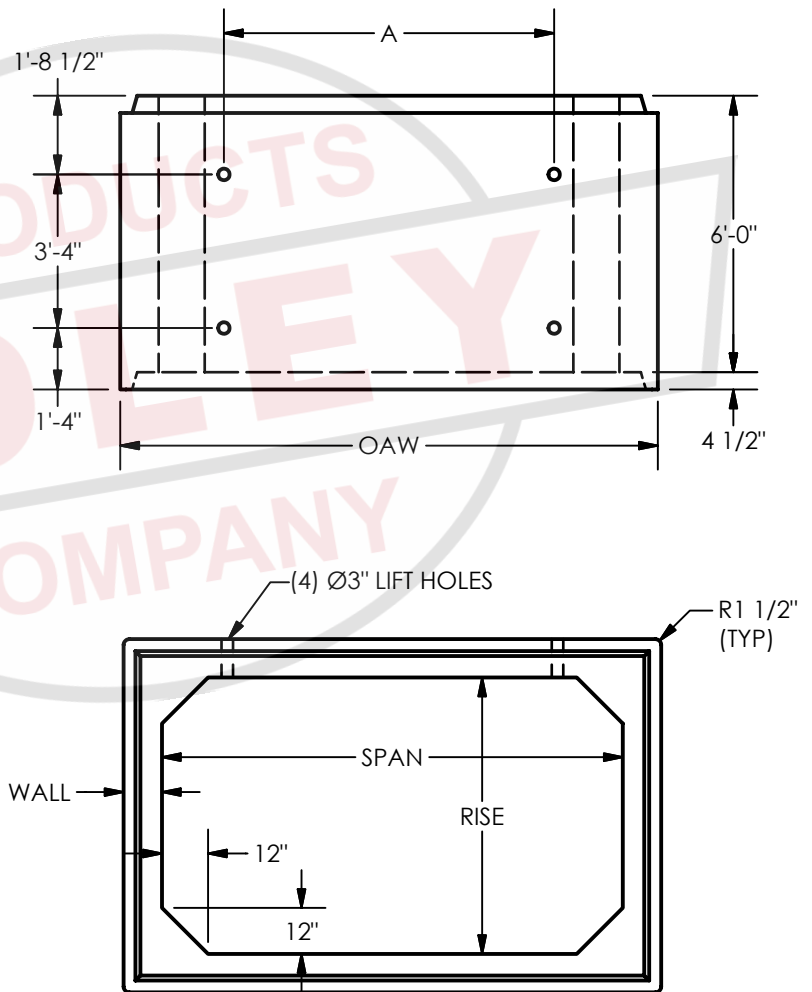
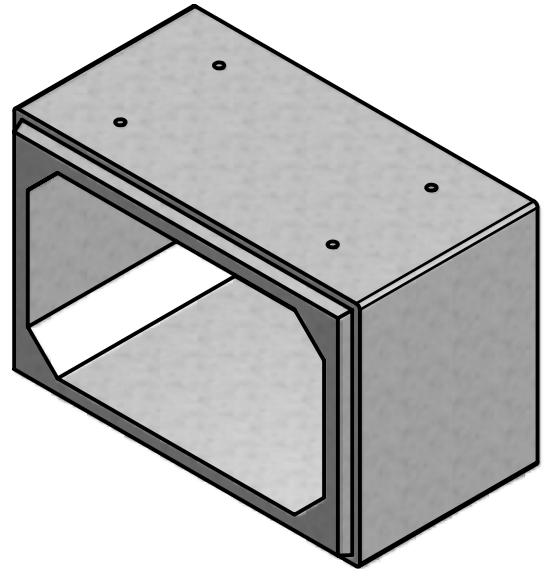

**MATERIALS:**

CONCRETE: 5,000 PSI, TYPE I/II CEMENT  
TYPICAL BOXES CONFORM TO ASTM C-1433

**NOTES:**

SPECIAL DESIGN BOX CULVERT AVAILABLE FOR INCREASED LOADS

**PARTS SHOWN:**

10'-0" x 6'-0" x 6'-0" SECTION BOX CULVERT



**BOX CULVERT**

BOX CULVERT STANDARD DETAIL

**4.1**