

GEORGIA DEPARTMENT OF
HUMAN RESOURCES
ENVIRONMENTAL HEALTH BRANCH
APPROVED: 10/31/2000

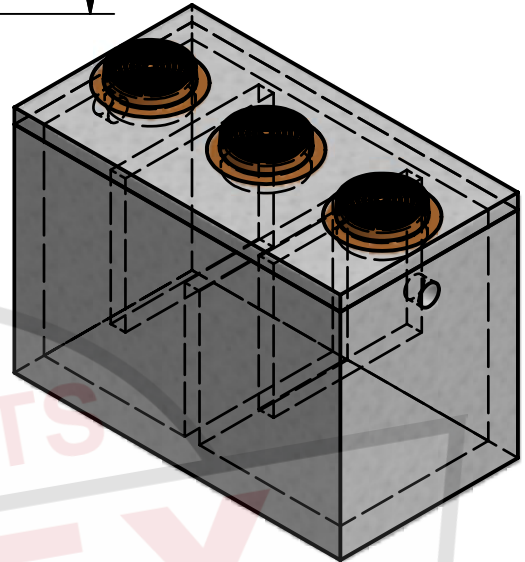

Ø26"
RING & COVER
(TYP)

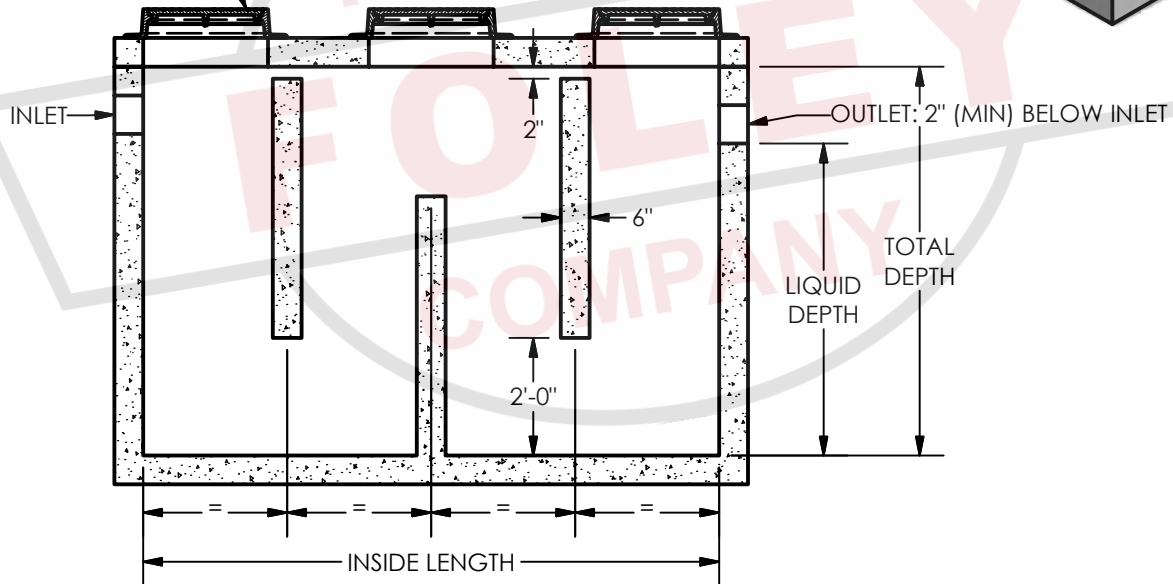

MATERIALS:

CONCRETE: 4,000 PSI, TYPE I/II CEMENT
MINIMUM #5 @ 12" O.C.E.W. - GRADE 60 REINFORCEMENT

NOTES:

AASHTO H20 DESIGN LOADING AVAILABLE

PARTS SHOWN:

2000 GALLON OIL WATER SEPARATOR
10.00' x 5.00' x 6.50'



BOX

OIL WATER SEPARATOR (STANDARD)

2.5