

| ID | WT | FLAT TOP | TONS | RISER SECTION | | | BASE SECTION | | |
|------|-----|----------|-------|---------------|----------|---------|--------------|----------|-----------|
| | | | | MAX | MIN | VF TONS | MAX | MIN | SLAB TONS |
| 60" | 6" | 8" | 1.41 | 5'-0" | 1'-0" | 0.65 | 5'-6" | 2'-0" | 1.41 |
| 72" | 7" | 9" | 2.27 | 6'-0" | 1'-0" | 0.91 | 6'-6" | 3'-0" ** | 2.02 |
| 84" | 7" | 12" | 3.93 | 8'-0" | 2'-0" * | 1.04 | 8'-6" | 3'-0" ** | 1.04 |
| 84" | 8" | 12" | 4.09 | N/A | N/A | N/A | 7'-6" | 3'-0" ** | 2.73 |
| 96" | 9" | 12" | 5.32 | 8'-0" | 2'-0" * | 1.55 | 8'-6" | 3'-0" ** | 3.54 |
| 120" | 10" | 12" | 8.02 | 6'-0" | 3'-0" ** | 2.13 | 5'-0" | 2'-0" | 10.69 |
| 120" | 11" | 12" | 8.25 | 8'-0" | 3'-0" ** | 2.36 | 7'-0" | 2'-0" | 11.00 |
| 144" | 12" | 12" | 11.55 | 6'-0" | 3'-0" ** | 3.06 | 5'-0" | 2'-0" | 17.32 |

1'-0" AVAILABLE UPON REQUEST *

2'-0" AVAILABLE UPON REQUEST **

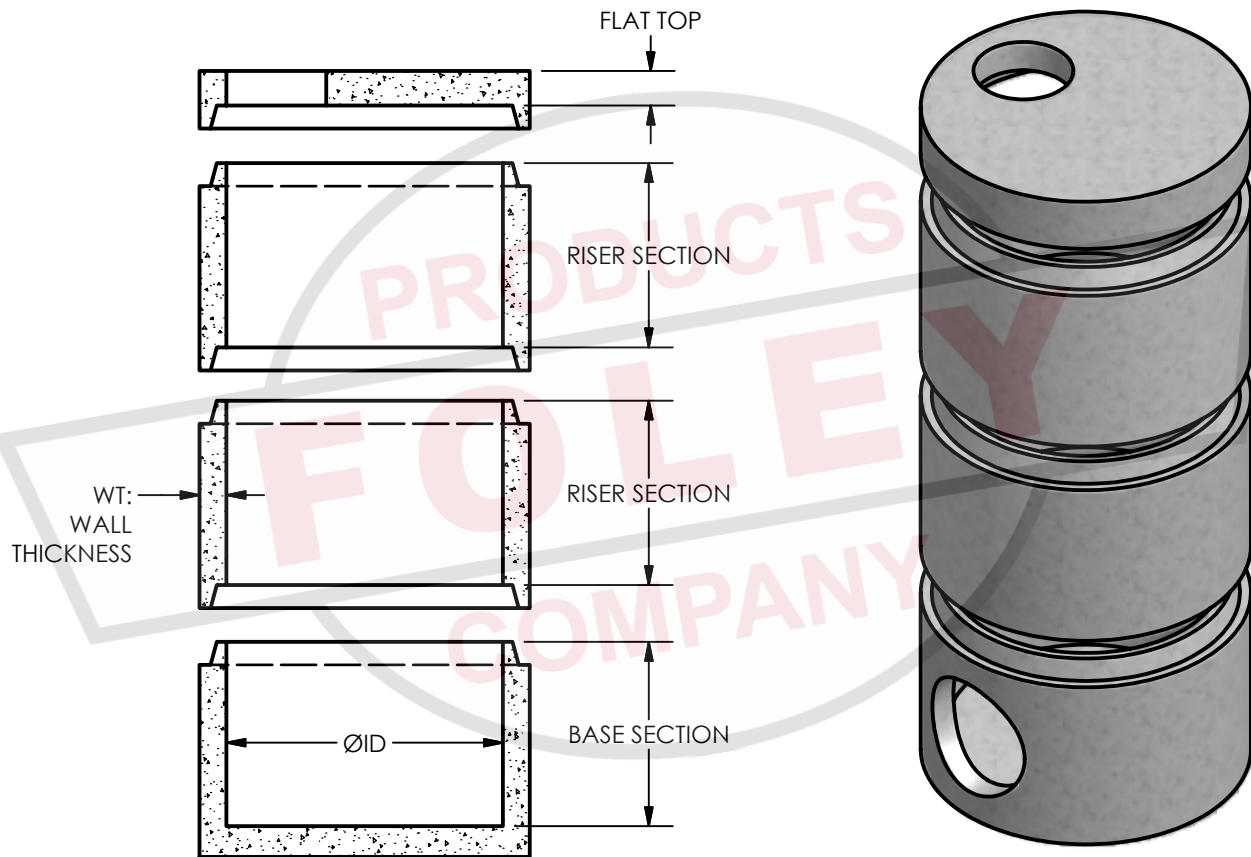

MATERIALS:

CONCRETE: 4,000 PSI, TYPE I/II CEMENT
 REINFORCEMENT PER ASTM C-478

NOTES:

FLEXIBLE CONNECTORS ARE AVAILABLE

PARTS SHOWN:

- Ø72" (7") FLAT TOP
- Ø72" (7") 4'-0" RISER
- Ø72" (7") 4'-0" RISER
- Ø72" (7") 4'-0" BASE W/ Ø34" HOLE



ROUND PRECAST

LARGE DIAMETER WET WELL

1.8